

BOTTOM VIEW: SOLDER SIDE

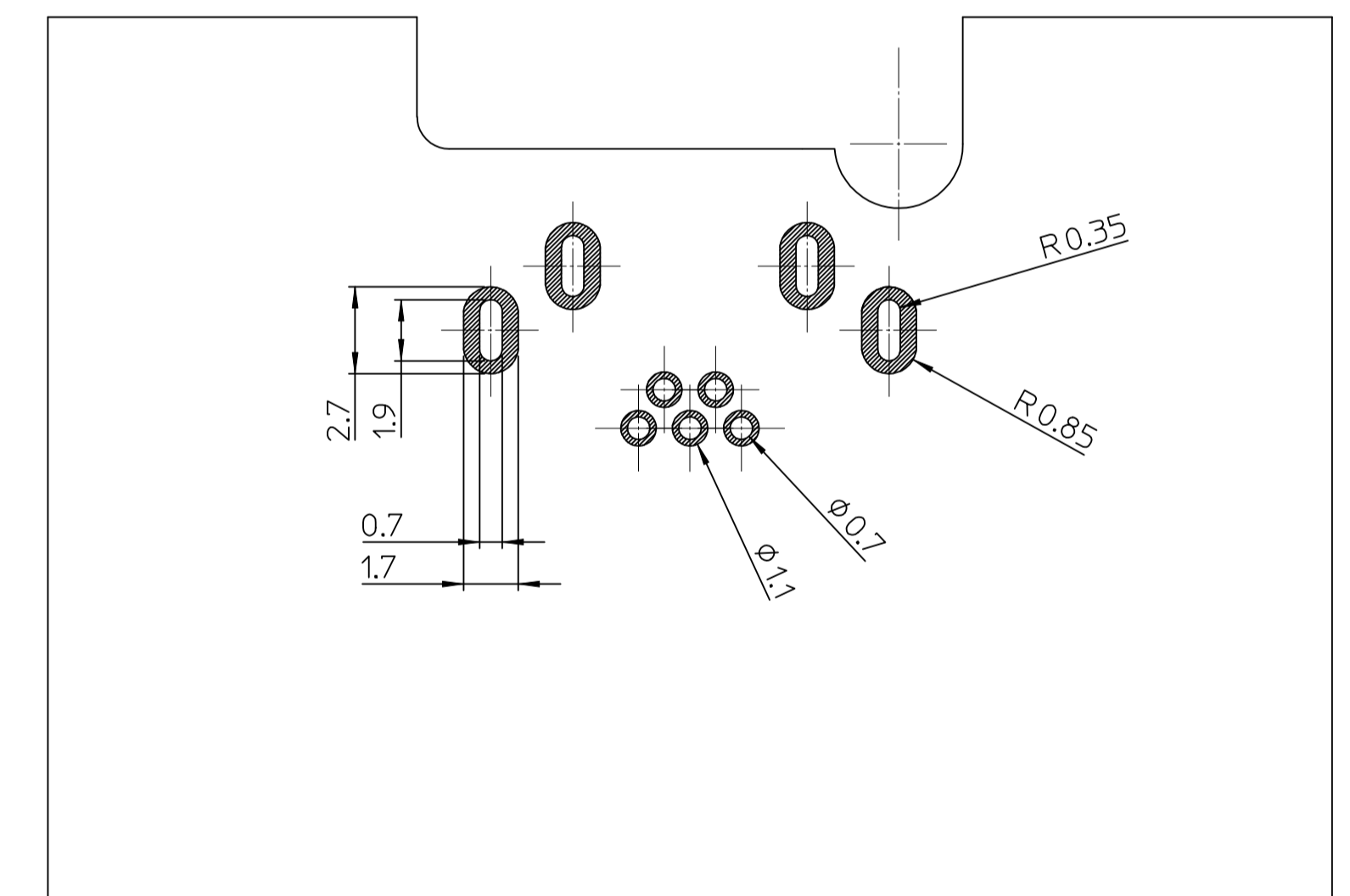

NOTES

- MATES WITH :
MOLEX SERIES NO. : 111014, 111015, 111005, 111041, 111019, 111020
- SHROUD GEOMETRY AND ASSEMBLY WITH USB MINI-B CONNECTOR ARE ACCORDING TO USCAR STD 999-U-USB-Z01
- FINISHES
 - TERMINAL :
CONTACT AREA : GOLD 0.75μm MIN.
SOLDER TAIL AREA : TIN 3.8μm MIN.
UNDER PLATING : NI 1.25μm MIN.
 - SHIELD CASE :
3.0μm MIN. TIN OVER NI 1.0μm MIN.
 - FITTING NAIL :
3.0μm MIN. TIN OVER NI 1.0μm MIN.
- UNLESS OTHERWISE SPECIFIED, TYPICAL RECOMMENDED PCB MANUFACTURING TOLERANCE IS ±0.05
- PCB THICKNESS : 1.6mm(REFERENCE)

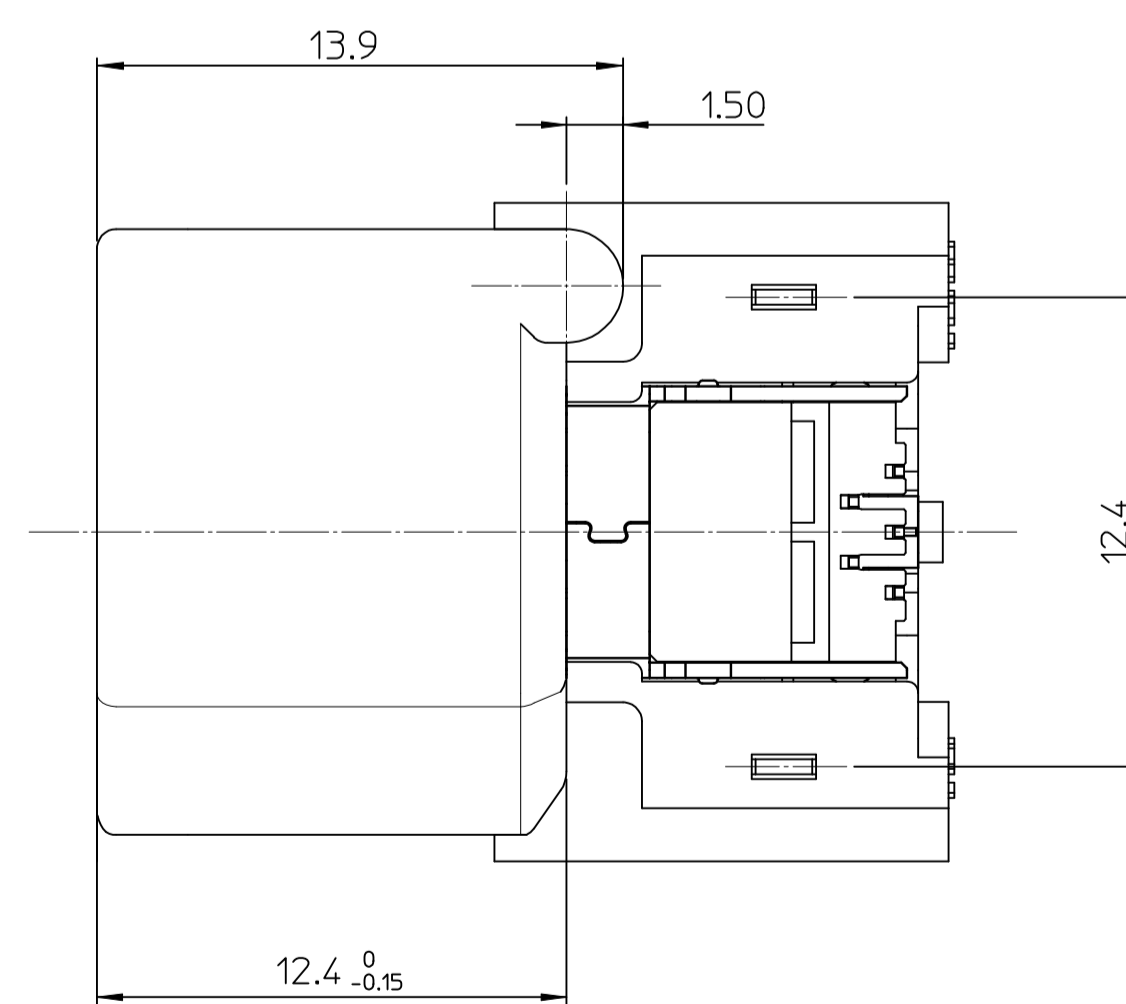

<PART LIST>

NO.	PART NAME	MATERIALS
①	SHROUD	SPS, GLASS FILLED, UL94 HB
②	REC. HOUSING	LCP, GLASS FILLED, UL94 V-0
③	TERMINAL	COPPER ALLOY
④	SHIELD CASE	PHOSPHOR BRONZE
⑤	FITTING NAIL	BRASS

RECOMMENDED PCB LAYOUT

<TABLE 1>

MATERIAL NO.	ORDER NO.	PACKAGING	COLOR
1040870801	104087-0801	TAPE & REEL	BLACK

DRAWING ERROR EC NO: KK1R220177-003333 DRWN: MK1M02 2017/01/14 CHKD: 2017/03/20 APPR: JHJANG	QUALITY SYMBOLS ∇=0 ∇=0 ∇=0	GENERAL TOLERANCES (UNLESS SPECIFIED)		DIMENSION STYLE MM ONLY		SCALE 5:1	DESIGN UNITS METRIC	THIRD ANGLE PROJECTION	
		4 PLACES ± --- ± --- 3 PLACES ± --- ± --- 2 PLACES ± 0.15 ± --- 1 PLACE ± 0.25 ± --- 0 PLACE ± --- ± ---	mm INCH	DRAWN BY HIMOON	DATE 2013/08/23	TITLE HSAUTOLINK R/A HEADER OPTION TYPE A (TAPE & REEL PACKING)			
		DRAFT WHERE APPLICABLE MUST REMAIN WITHIN DIMENSIONS		CHECKED BY BCY00N	DATE 2013/08/23	molex			
		ANGULAR ± 1 °		APPROVED BY JYCHO1	DATE 2013/09/04	MATERIAL NO. SEE TABLE 1		DOCUMENT NO. RSD-104087-007	SHEET NO. 1 OF 2

THIS DRAWING CONTAINS INFORMATION THAT IS PROPRIETARY TO MOLEX INCORPORATED AND SHOULD NOT BE USED WITHOUT WRITTEN PERMISSION

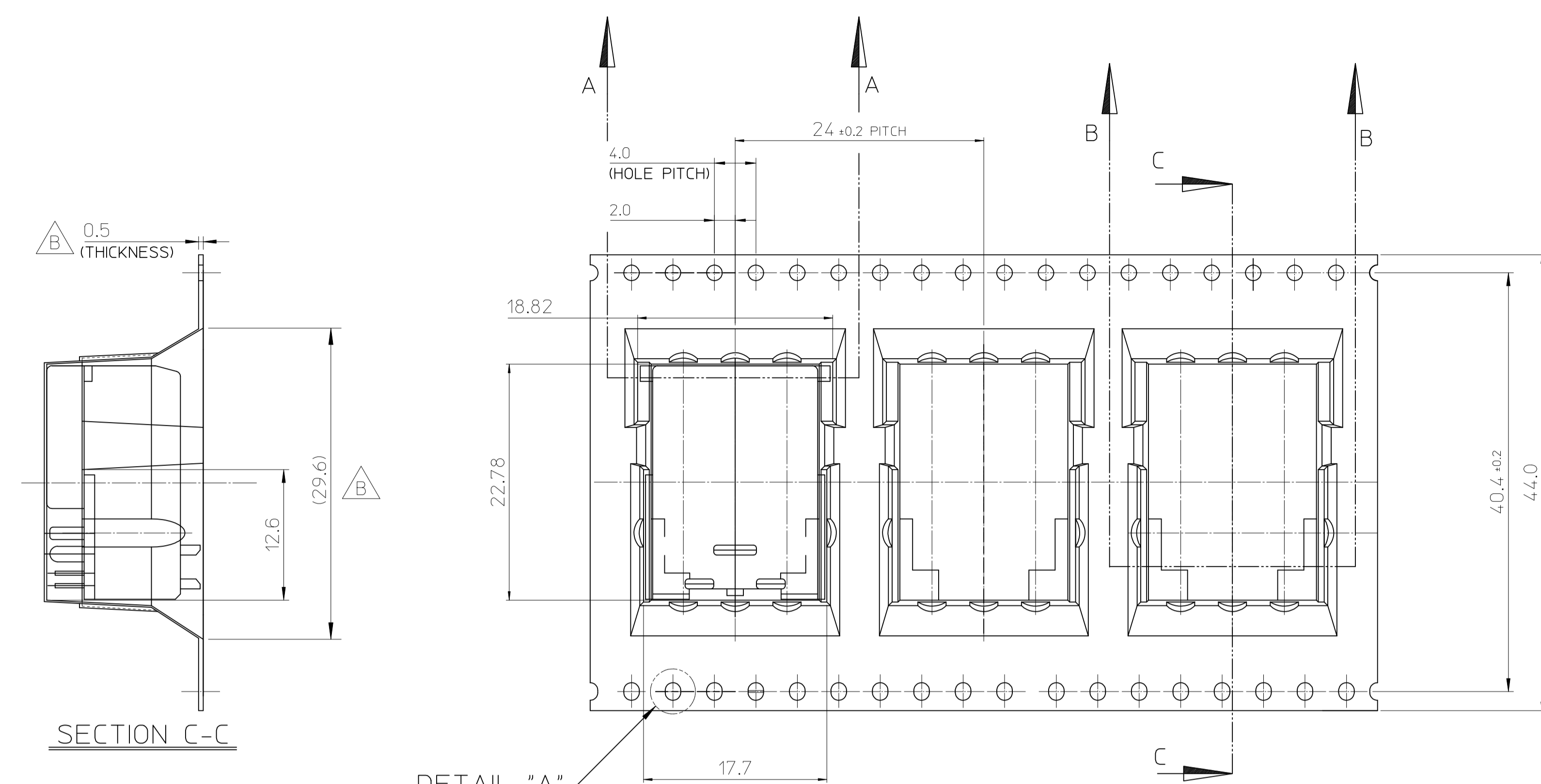

EMBOSS TAPE

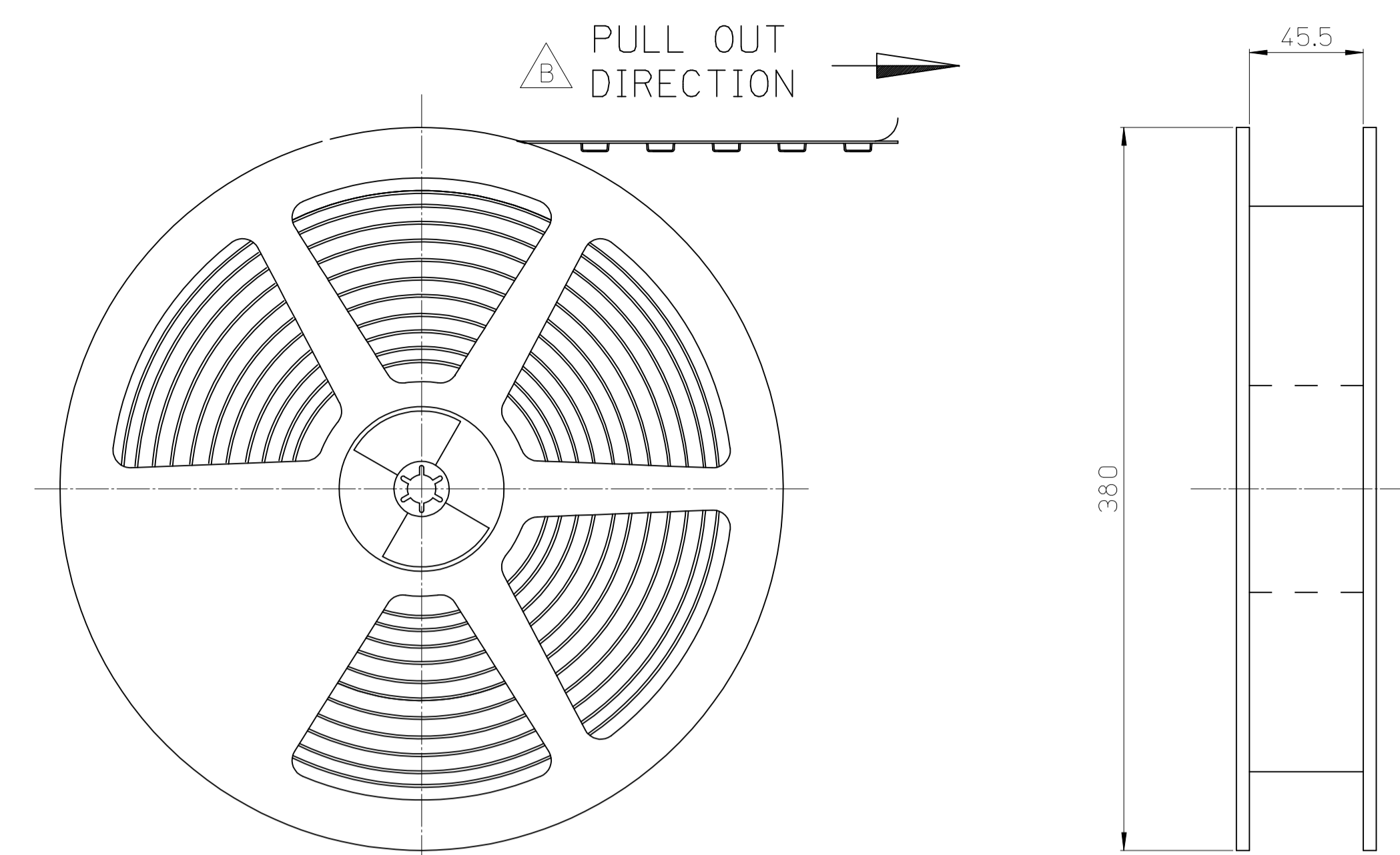

PLASTIC BOBBIN

NOTES

1. QUANTITY OF CONNECTORS : 200EA/REEL
2. MATERIAL
 - EMBOSS TAPE : P.E.T ANTISTATIC
 - PASTIC BOBBIN : P.S

3. LEAD LENGTH

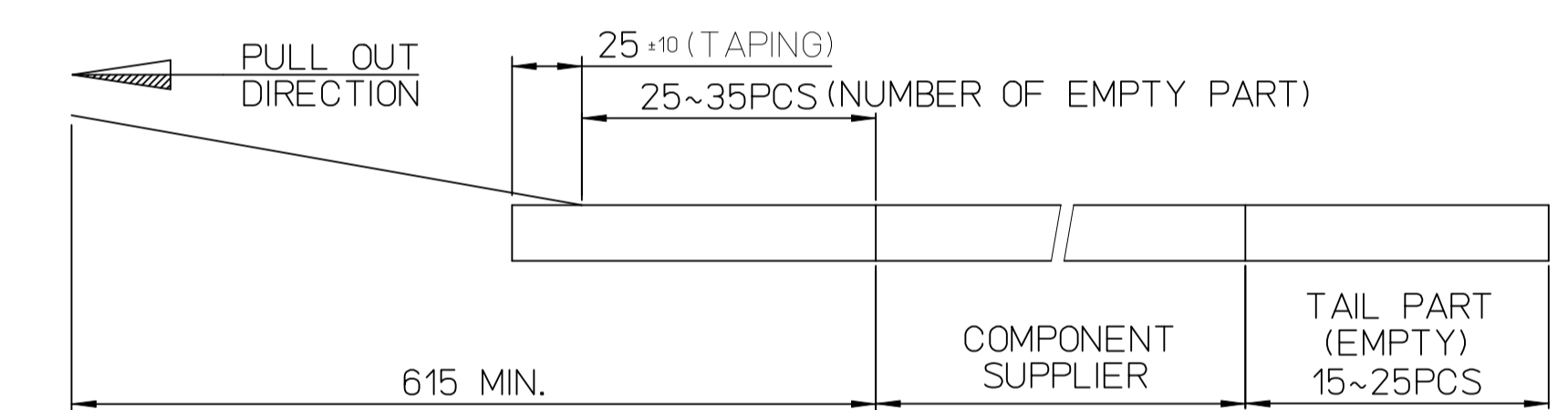

4. PEELING OFF FORCE OF COVER TAPE : 0.1N~0.59N(10.2GF~60GF)
(PEELING DIRECTION AS SHOW IN FOLLOW FIG.)
PEELING OFF SPEED : 300mm/Min.(Ref.)

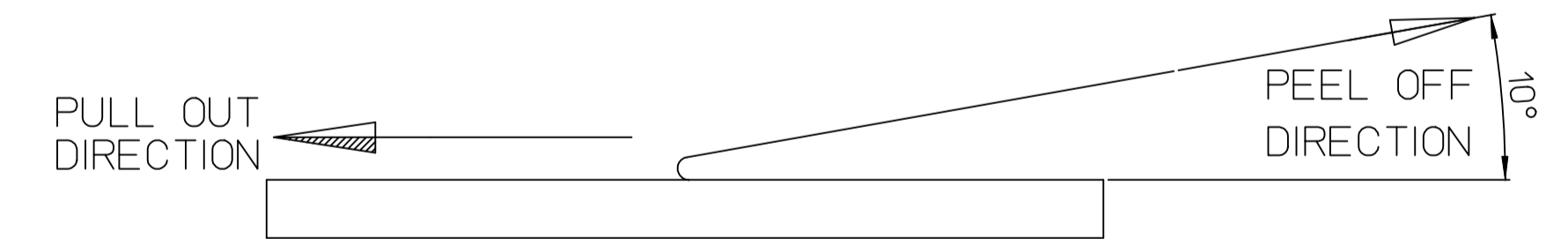

5. FLASH IN ANY PORTION SHOULD BE LESS THAN 0.20mm MAX.

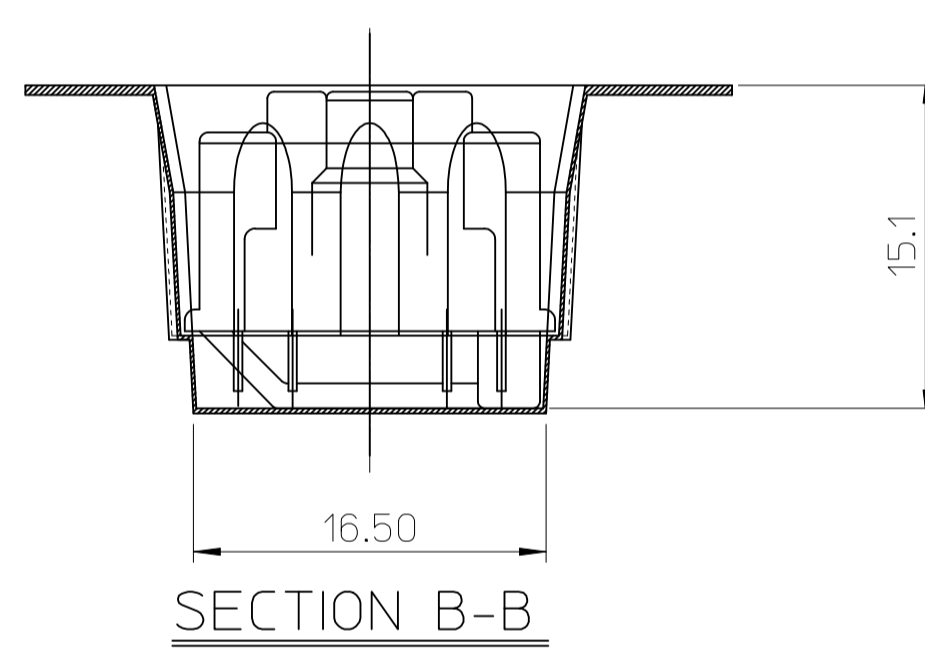
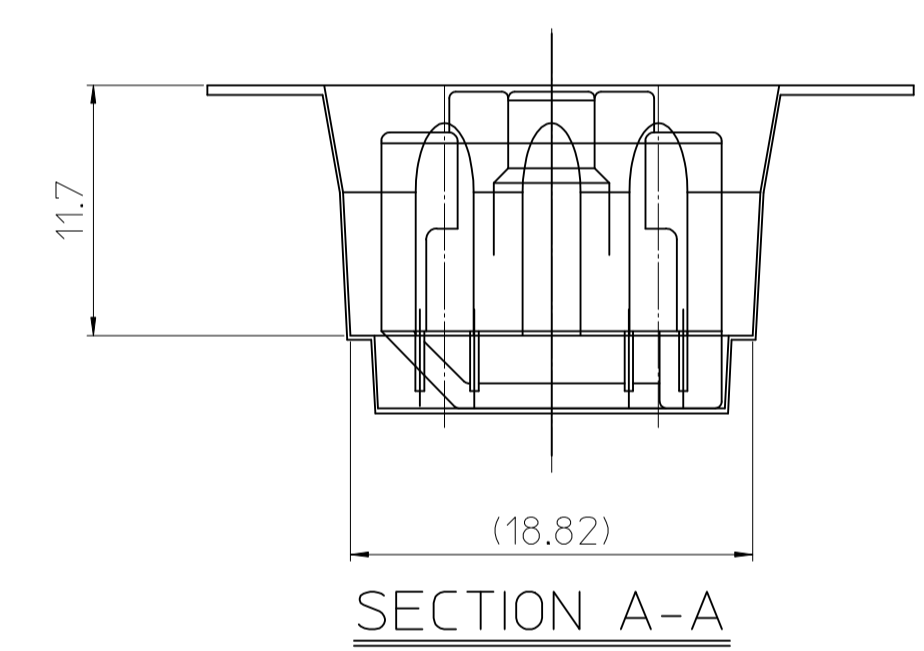
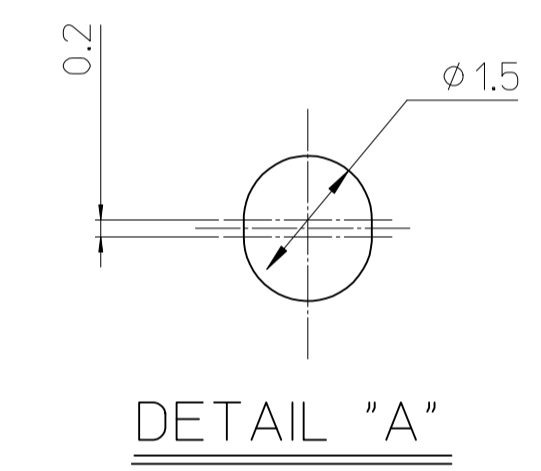

DRAWING ERROR EC NO: KTR2017-0033 DRWN: JWK IM02 2017/01/14 CH'KD: APPR: JHJANG 2017/03/20	QUALITY SYMBOLS	GENERAL TOLERANCES (UNLESS SPECIFIED)	DIMENSION STYLE MM ONLY	SCALE 5:1	DESIGN UNITS METRIC	THIRD ANGLE PROJECTION
	▽=0	4 PLACES ± --- ± ---	DRAWN BY HIMOON	DATE 2013/08/23	TITLE HSAUTOLINK R/A HEADER OPTION TYPE A (TAPE & REEL PACKING)	
	▽=0	3 PLACES ± --- ± ---	CHECKED BY BCYOON	DATE 2013/08/23	molex DOCUMENT NO. RSD-104087-007 SHEET NO. 2 OF 2	
	▽=0	2 PLACES ± 0.15 ± ---	APPROVED BY JYCHOI	DATE 2013/09/04		
		1 PLACE ± 0.25 ± ---	ANGULAR ± 1 °	MATERIAL NO. SEE TABLE 1	SIZE A2	THIS DRAWING CONTAINS INFORMATION THAT IS PROPRIETARY TO MOLEX INCORPORATED AND SHOULD NOT BE USED WITHOUT WRITTEN PERMISSION
	0 PLACE ± --- ± ---	DRAFT WHERE APPLICABLE MUST REMAIN WITHIN DIMENSIONS				