

Cable ID for USB Type-C Cables

General Description

The RT1731 is Electronically-Marked ID cables IC for both passive and active full-featured USB Type-C cable controller complies with USB type-C and Power Delivery application, the Electronically-Marked ID cables support USB Power Delivery Structured VDM Discover Identity command directed to SOP'. With Electrically-Marked Cable ID, the DFP host can determine the characteristics of the cable, e.g. its current carrying capability, its performance, and vendor identification, the RT1731 features VBUS short protection on VCONN and CCIN to avoid pin short when VBUS voltage rises above 20V after PD communication is complete.

The RT1731 is available in WDFN-8L 2x2 and WL-CSP-8B 0.96x1.64 (BSC) packages.

Ordering Information

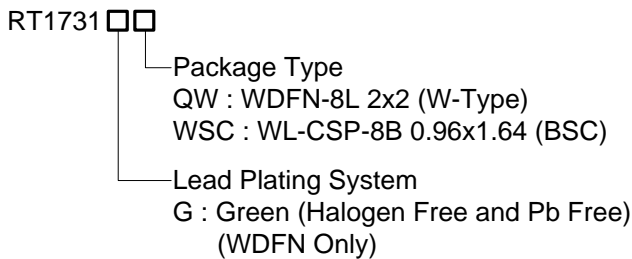

Note :

Richtek products are :

- ▶ RoHS compliant and compatible with the current requirements of IPC/JEDEC J-STD-020.
- ▶ Suitable for use in SnPb or Pb-free soldering processes.

Features

- **Type-C Support/PD Support**
 - ▶ Support SOP' and SOP'' Communication
 - ▶ Support Host Authentication
 - ▶ Support Additional Modal Operation
- **Advantage**
 - ▶ Embedded Both Side RA Resistor
 - ▶ Embedded Both Side ISO Diode
 - ▶ Support Multi-Time Writable Memory to Store VDM Data
 - ▶ Support Custom Structured VDM Writing Over CC Pin
 - ▶ Write Protect on Multi One-Time Programmable (OTP) Memory
 - ▶ Support I²C Bus for Programming VDM Data
- **Power**
 - ▶ Support 3V to 5.5V Operation on VCON1/VCON2 Pin
- **Protection**
 - ▶ HV Protection of VCON1/VCON2/CCIN
- **Package**
 - ▶ WDFN-8L 2x2
 - ▶ WL-CSP-8B 0.96x1.64 (BSC)

Applications

- USB Full-Featured Type-C Cables
- Type-C Active Cable
- Type-C Passive Cable

Simplified Application Circuit

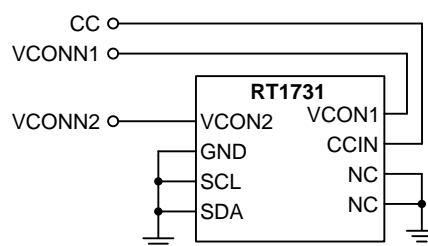

Marking Information

RT1731GQW

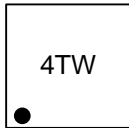

4T : Product Code
W : Date Code

RT1731WSC

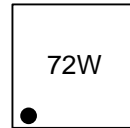

72 : Product Code
W : Date Code

Pin Configuration

(TOP VIEW)

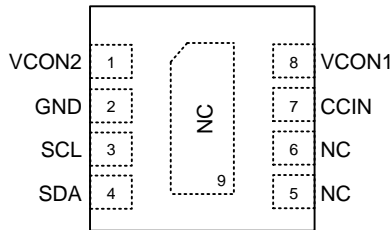

WDFN-8L 2x2

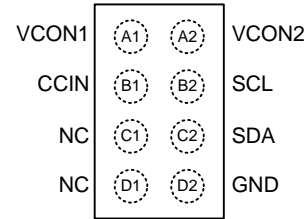

WL-CSP-8B 0.96x1.64 (BSC)

Functional Pin Description

Pin No.		Pin Name	Pin Function
WDFN-8L 2x2	WL-CSP-8B 0.96x1.64 (BSC)		
1	A2	VCON2	The power is input pin supplied from VCONN with resistor RA termination and has high voltage protection at 22V.
2	D2	GND	Ground pin.
3	B2	SCL	This pin is only used for debug. No internal connection. (Recommend to connect to GND)
4	C2	SDA	This pin is only used for debug. No internal connection. (Recommend to connect to GND)
5, 6	C1, D1	NC	No internal connection. (Recommend to connect to GND)
7	B1	CCIN	The configuration channel pin used in the discovery, configuration and management of connections, includes high voltage protection at 22V.
8	A1	VCON1	The power is input pin supplied from VCONN with resistor RA termination and has high voltage protection at 22V.
9 (Exposed Pad)	--	NC	No internal connection. The exposed pad must be soldered to a large PCB and connected to GND for maximum power dissipation.

Functional Block Diagram

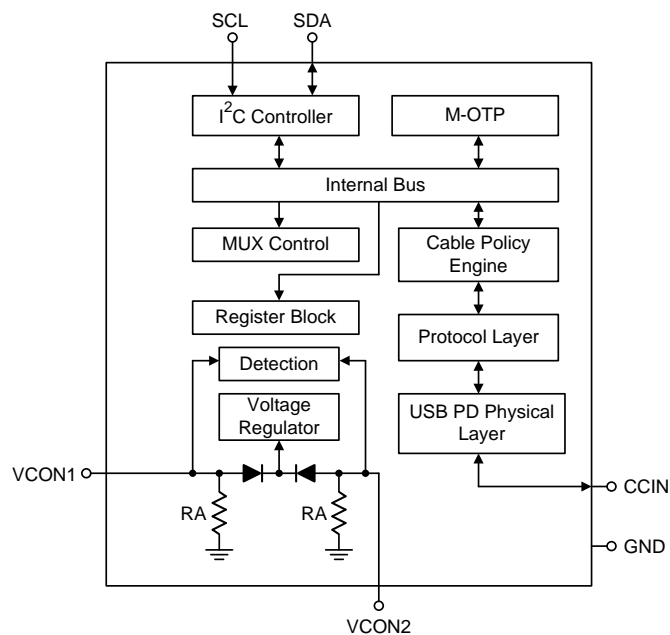

Operation

SOP' and SOP'' Communication

A Cable Plug capable of SOP' Communication shall only detect and communicate with packets starting with SOP'. The eMarker in a Passive Cable shall be capable of SOP' Communication only after VCONN is on. Or the eMarker in an Active Cable shall be capable of SOP' Communication only after VCONN is on and SOP'' Controller is not present.

A Cable Plug capable of SOP'' Communication shall have a SOP' Communication capability in the other Cable Plug. No cable shall only support SOP'' Communication. A Cable Plug to which SOP'' Communication is assigned shall only detect and communicate with packets starting with SOP''. The eMarker in an Active Cable with SOP'' Controller present will support SOP' communication in one Cable Plug and SOP'' communication in the other Cable Plug. The term Cable Plug in the SOP' Communication and SOP'' Communication case is used to represent a logical entity (RT1731) in the cable which is capable of PD Communication.

PD Modal Operation

The RT1731 supports PD Model operation when the feature of Mode Enter/Exit process is specified, e.g.

40Gbps Model operation. There are several SVID/MODE configuration setting to supports up to 3 kinds of Modal operation (40Gbps Modal Operation included). Flexibility is retained for new applications in the feature.

PD 3.0 Compliance

The RT1731 supports PD3.0 Get_Status capability. Customized response above will be returned. The RT1731 also support Active Cable VDO and Active Cable VDO2 response when product is configured as PD3.0, Active Cable VDO version = 1.2 and act as Active Cable.

Proprietary Authentication

Proprietary Authentication is supported with cooperating Device, TA, etc., that need certain authentication before enabling proprietary charging or customized function to ensure Cable Plug's reliability and quality.

Inter-Frame Gap Timings

The transmitter (Host command) shall drive the bus for no longer than t_{EndDriveBMC} after transmitting the final bit of the Frame.

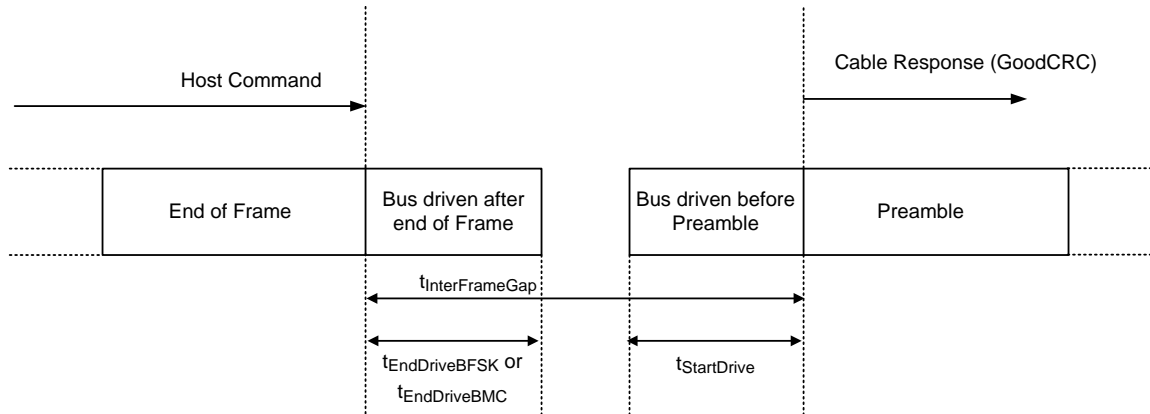

Figure1. Inter-Frame Gap Timings

The GoodCRC Message shall be sent by the receiver to acknowledge that the previous Message was correctly received (i.e. had a good CRC). The GoodCRC Message shall return the Message’s MessageID so the transmitter can determine that the correct Message is being acknowledged. The first bit of the GoodCRC Message shall be returned within $t_{Transmit}$ after receipt of the last bit of the previous Message.

BMC Encoded Start of Preamble

The transmitter may vary the start of the Preamble by $t_{StartDrive}$ min. When sending the Preamble, the transmitter shall start by transmitting a low level. The receiver shall tolerate the loss of the first edge.

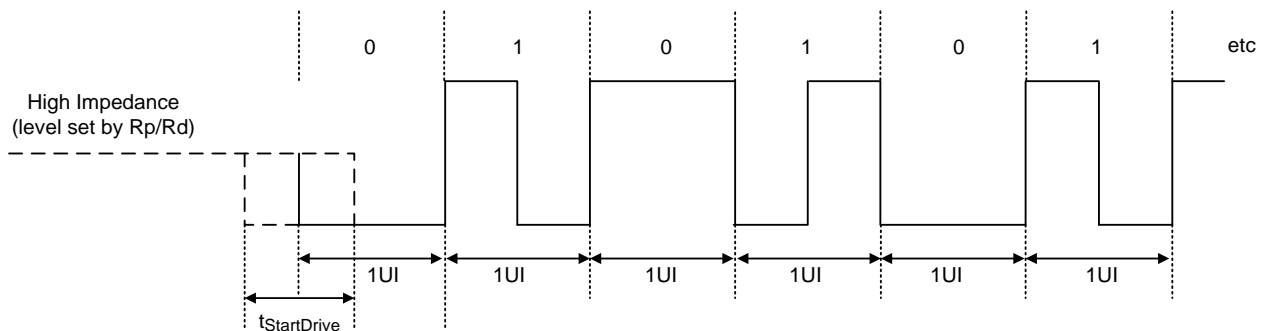

Figure 2. BMC Encoded Start of Preamble

Transmitting or Receiving BMC Encoded Frame Terminated

The end of a BMC encoded Frame with an encoded zero for which the final bit of the Frame is terminated by a high to low transition.

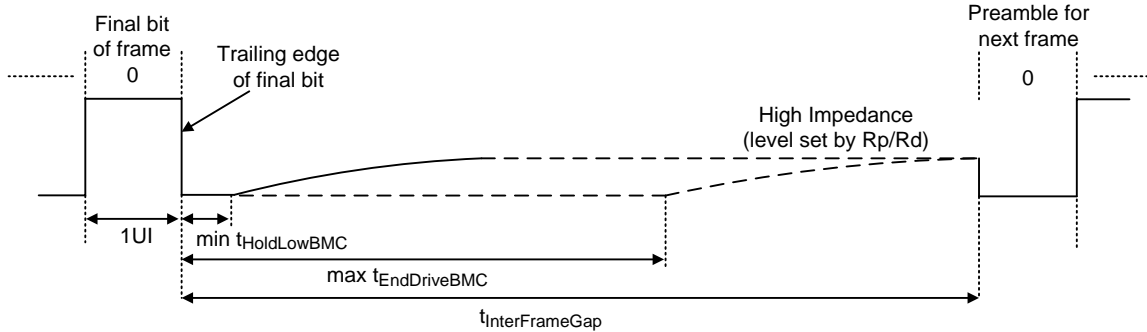

Figure 3. $t_{InterFrameGap}$

Biphase Mark Coding (BMC) Signaling Scheme

Biphase Mark Coding is the physical layer Signaling Scheme for carrying USB Power Delivery Messages. This encoding assumes a dedicated DC connection, identified as the CC wire, which is used for sending PD Messages.

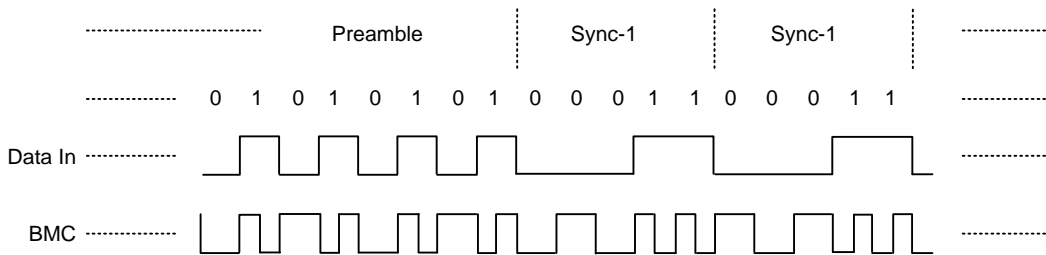

Figure 4. BMC Example

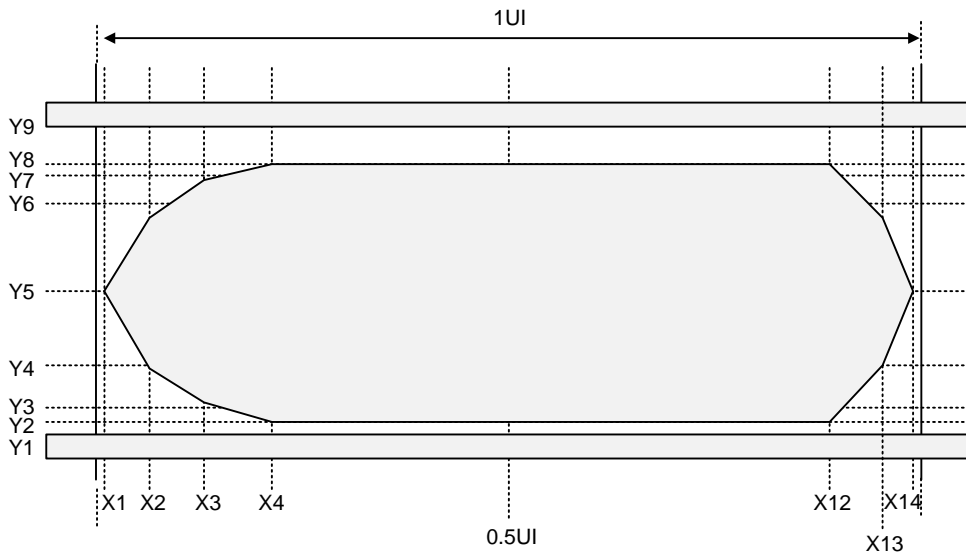

Figure 5. BMC Tx 'ZERO' Mask

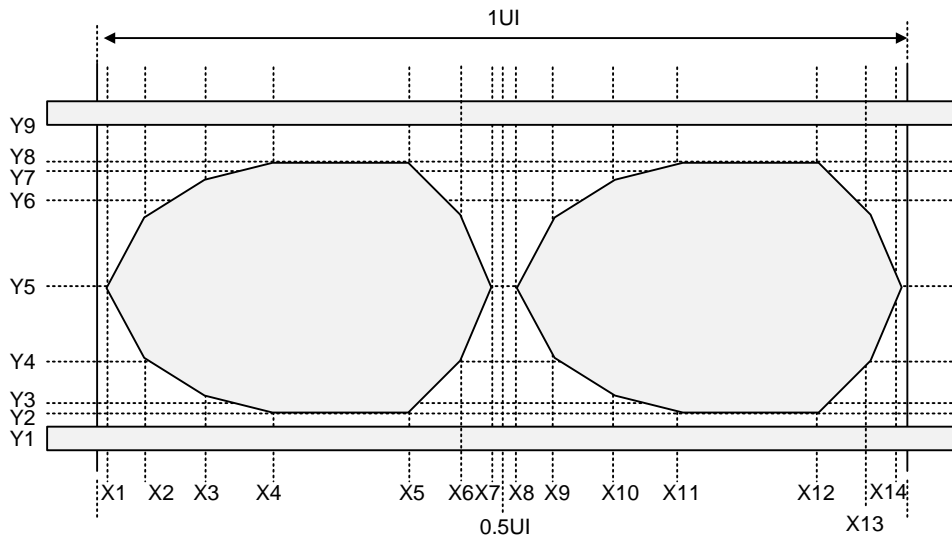

Figure 6. BMC Tx 'ONE' Mask

Table 1. BMC Tx Mask Definition and X Values

BMC TC Mask Definition, X Values			
Parameter	Symbol	Value	Unit
Left Edge of Mask	X1Tx	0.015	UI
X2Tx point	X2Tx	0.07	UI
X3Tx point	X3Tx	0.15	UI
X4Tx point	X4Tx	0.25	UI
X5Tx point	X5Tx	0.35	UI
X6Tx point	X6Tx	0.43	UI
X7Tx point	X7Tx	0.485	UI
X8Tx point	X8Tx	0.515	UI
X9Tx point	X9Tx	0.57	UI
X10Tx point	X10Tx	0.65	UI
X11Tx point	X11Tx	0.75	UI
X12Tx point	X12Tx	0.85	UI
X13Tx point	X13Tx	0.93	UI
Right Edge of Mask	X14Tx	0.985	UI

Table 2. BMC Tx Mask Definition and Y Values

BMC TC Mask Definition, Y Values			
Parameter	Symbol	Typ	Unit
Lower Bound of Outer Mask	Y1Tx	-0.075	V
Lower Bound of Inner Mask	Y2Tx	0.075	V
Y3Tx Point	Y3Tx	0.15	V
Y4Tx Point	Y4Tx	0.325	V
Inner Mask Vertical Midpoint	Y5Tx	0.5625	V
Y6Tx Point	Y6Tx	0.8	V
Y7Tx Point	Y7Tx	0.975	V
Y8Tx Point	Y8Tx	1.04	V
Upper Bound of Outer Mask	Y9Tx	1.2	V

Absolute Maximum Ratings (Note1)

- VCON1/VCON2/CCIN ----- -0.3V to 22V
- SCL/SDA ----- -0.3V to 6V
- Power Dissipation, P_D @ T_A = 25°C
 - WDFN-8L 2x2 ----- 2.19W
 - WL-CSP-8B 0.96x1.64 (BSC) ----- 0.93W
- Package Thermal Resistance (Note 2)
 - WDFN-8L 2x2, θ_{JA} ----- 45.5°C/W
 - WDFN-8L 2x2, θ_{JC} ----- 11.5°C/W
 - WL-CSP-8B 0.96x1.64 (BSC), θ_{JA} ----- 106.5°C/W
- Lead Temperature (Soldering, 10 sec.) ----- 260°C
- Junction Temperature ----- 150°C
- Storage Temperature Range ----- -65°C to 150°C
- ESD Susceptibility (Note 3)
 - HBM (Human Body Model)
 - VCON1/VCON2/CCIN ----- 8kV
 - Others ----- 2kV

Recommended Operating Conditions (Note 4)

- Supply Input Voltage ----- 3V to 5.5V
- Ambient Temperature Range ----- -40°C to 85°C
- Junction Temperature Range ----- -40°C to 125°C

Electrical Characteristics

(V_{DD} = 5V, T_A = 25°C, unless otherwise specified)

Parameter	Symbol	Test Conditions	Min	Typ	Max	Unit
BMC Signaling						
Bit rate	f _{BitRate}	V _{CONN} = 3V to 5.5V	270	300	330	Kbps
Maximum difference between the bit-rate during the part of the packet following the Preamble and the reference bit-rate.	ρ _{BitRate}	V _{CONN} = 3V to 5.5V	--	--	0.25	%
Time from the end of last bit of a Frame until the start of the first bit of the next Preamble.	t _{InterFrameGap}	V _{CONN} = 3V to 5.5V	25	--	--	μs
Time before the start of the first bit of the Preamble when the transmitter shall start driving the line.	t _{StartDrive}	V _{CONN} = 3V to 5.5V	-1	--	1	μs
BMC Common Normative						
Time to cease driving the line after the end of the last bit of the Frame.	t _{EndDriveBMC}	V _{CONN} = 3V to 5.5V	--	--	23	μs

Parameter	Symbol	Test Conditions	Min	Typ	Max	Unit
Fall Time	t _{Fall}	V _{CONN} = 3V to 5.5V	300	--	--	ns
Time to cease driving the line after the final high-to-low transition	t _{HoldLowBMC}	V _{CONN} = 3V to 5.5V	1	--	--	μs
Rise Time	t _{Rise}	V _{CONN} = 3V to 5.5V	300	--	--	ns
Voltage Swing	V _{Swing}	V _{CONN} = 3V to 5.5V	1.05	1.125	1.2	V
Transmitter Output Impedance	Z _{Driver}	V _{CONN} = 3V to 5.5V	33	--	75	Ω
BMC Receiver Normative						
Cable Termination	R _A	V _{CONN} = 3V to 5.5V	800	--	1200	Ω
Receiver Input Impedance	Z _{BmcRx}	V _{CONN} = 3V to 5.5V	1	--	--	MΩ
BIST Mode						
Supply Current	I _{supply}	Typical values measured at V _{CONN1} or V _{CONN2} = 5V	--	9.5	--	mA
Stand-by Mode						
Supply Current	I _{supply-by}	Typical values measured at V _{CONN1} or V _{CONN2} = 5V	--	1.6	--	mA

Note 1. Stresses beyond those listed under “Absolute Maximum Ratings” may cause permanent damage to the device. These are stress ratings only, and functional operation of the device at these or any other conditions beyond those indicated in the operational sections of the specifications is not implied. Exposure to absolute maximum rating conditions may affect device reliability.

Note 2. θ_{JA} is measured under natural convection (still air) at T_A = 25°C with the component mounted on a high effective-thermal-conductivity four-layer test board on a JEDEC 51-7 thermal measurement standard. θ_{JC} is measured at the exposed pad of the package.

Note 3. Devices are ESD sensitive. Handling precaution is recommended.

Note 4. The device is not guaranteed to function outside its operating conditions.

Typical Application Circuit

Electronically Marked Cable with VCONN connected through the cable (Passive cable application)

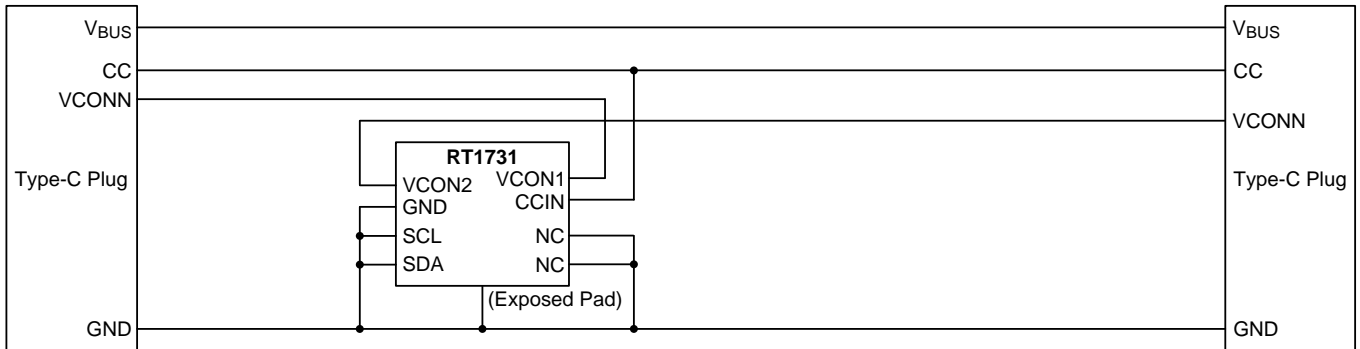

Electronically Marked Cable with SOP' at both ends (Passive cable application)

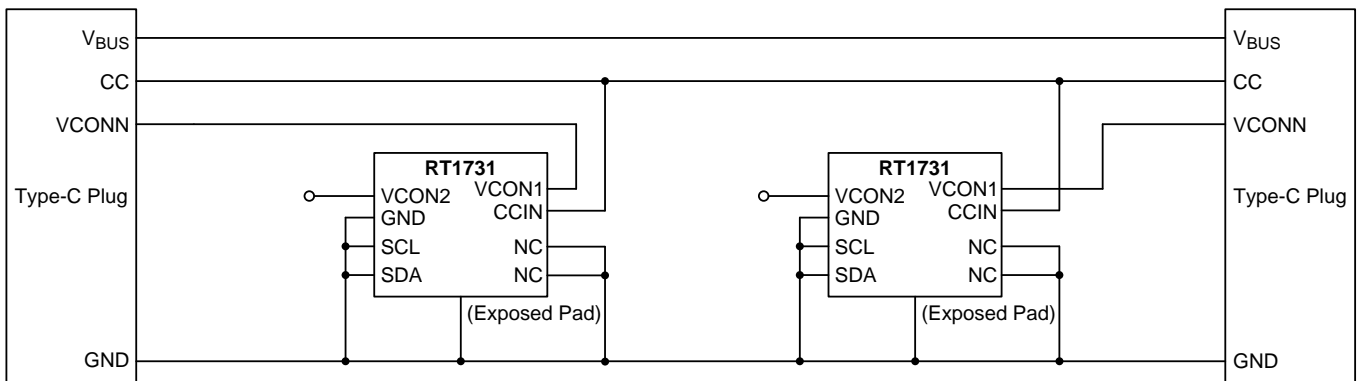

Application Information

Start of Packet Sequence Prime (SOP')

The SOP' ordered set is defined as : two Sync-1 K-codes followed by two Sync-3 K-codes

K-code Number	K-code in Code Table
1	Sync-1
2	Sync-1
3	Sync-3
4	Sync-3

A Cable Plug capable of SOP' Communications shall only detect and communicate with packets starting with SOP'.

A DFP or Source needing to communicate with a Cable Plug capable of SOP' Communications, attached between a Port Pair will be able to communicate using both packets starting with SOP' to communicate with the Cable Plug and starting with SOP to communicate with its Port Partner. The DFP or Source shall co-ordinate SOP and SOP' Communication so as to avoid collisions.

Start of Packet Sequence Double Prime (SOP'')

The SOP'' ordered set is defined as the following sequence of K-codes : Sync-1, Sync-3, Sync-1, Sync-3

K-code Number	K-code in Code Table
1	Sync-1
2	Sync-3
3	Sync-1
4	Sync-3

A Cable Plug capable of SOP'' Communication, shall have a SOP' Communication capability in the other Cable Plug. No cable shall only support SOP'' Communication. A Cable Plug to which SOP''

Communication is assigned shall only detect and communicate with packets starting with SOP'' and shall Discard any other packets.

A Port needing to communicate with such a Cable Plug, Attached between a Port Pair will be able to communicate using packets starting with SOP' and SOP'' to communicate with the Cable Plugs and packets starting with SOP to communicate with its Port Partner.

Structured VDM

Setting the VDM Type field to 1 (Structured VDM) defines the use of bits Bit[14:0] in the Structured VDM Header. The fields in the Structured VDM Header are defined in Table.

The following rules apply to the use of Structured VDM messages :

- Structured VDMs shall only be used when an Explicit Contract is in place with the following exception :
Prior to establishing an Explicit Contract a Source may issue Discover Identity messages, to a Cable Plug using SOP' Packets, as an Initiator.
- Only the DFP shall be an Initiator of Structured VDMs except for the Attention Command that shall only be initiated by the UFP.
- Only the UFP or a Cable Plug shall be a Responder to Structured VDMs.
- Structured VDMs shall not be initiated or responded to under any other circumstances.
- A DFP or UFP which does not support Structured VDMs shall ignore any Structured VDMs received.
- A Command sequence shall be interruptible e.g. due to the need for a message sequence using SOP Packets.

Bit(s)	Field	Description
Bit[31:16]	Standard or Vendor ID (SVID)	Unique 16-bit unsigned integer, assigned by the USB-IF
Bit[15]	VDM Type	1 = Structured VDM
Bit[14:13]	Structured VDM Version	Version number of the structured VDM (not this specification Version) 00b = Version 1.0 (shall not be used) 01b = Version 2.0 Values = 10, 11 are Reserved and shall not be used

Bit(s)	Field	Description
Bit[12:11]	Reserved	For Commands 0...15 shall be set to 0 and shall be ignored SVID specific commands (16...31) defined by the SVID.
Bit[10:8]	Object Position	For the enter mode, exit mode and attention commands (requests/responses) : 000b = Reserved and shall not be used. 001b...110b = Index into the list of VDOs to identify the desired Mode VDO 111b = Exit all Active Modes (equivalent of a power on reset). Shall only be used with the exit mode command. Commands 0...3, 7...15 : 000b 001b...111b = Reserved and shall not be used. SVID specific commands (16...31) defined by the SVID.
Bit[7:6]	Command Type	00b = REQ (Request from initiator port) 01b = ACK (Acknowledge response from responder port) 10b = NAK (Negative acknowledge response from responder port) 11b = BUSY (Busy response from responder port)
Bit[5]	Reserved	0 : Reserved, shall not be used
Bit[4:0]	Command (Note 5)	0 = Reserved, shall not be used 1 = Discover identity 2 = Discover SVIDs 3 = Discover modes 4 = Enter mode 5 = Exit mode 6 = Attention 7-15 = Reserved, shall not be used 16..31 = SVID specific commands
Note 5 : In the case where a SID is used the modes are defined by a standard. When a VID is used the modes are defined by the Vendor.		

Discover Identity

The Discover Identity Command is provided to enable an Initiator (DFP) to identify its Port Partner and for an Initiator (Source or DFP) to identify the attached Cable Plug (Responder).

The SVID in the Discover SVIDs Command shall be set to the PD SID by both the Initiator and the Responder for this Command.

The *Discover Identity* Command sent back by the Responder contains an ID Header, a Cert Stat VDO and some Type specific VDOs which depend on the Product Type. This specification defines the following Type specific VDOs :

Header No. of Data Objects = 4-7 ¹	VDM Header	ID Header	Cert Stat VDO	Product VDO	0..3 ² Product Type VDO(s)
--	---------------	--------------	---------------	-------------	--

1. Only Data objects defined in this specification can be sent as part of the Discover Identity Command.
2. The following sections define the number and content of the VDOs for each Product Type.

The Number of Data Objects field in the Message Header in the Discover Identity Command NAK and BUSY responses shall be set to 1 since they shall not contain any VDOs.

ID Header

The ID Header contains the vendor ID corresponding to the Power Delivery Product.

Bit(s)	Description
Bit[31]	USB communications capable as USB host : 0b : Otherwise 1b : The product is capable of enumerating USB devices.
Bit[30]	USB communications capable as a USB device : 0b : Otherwise 1b : The product is capable of being enumerated as a USB device.
Bit[29:27]	Product type (cable plug) : 000b : Undefined 001b...010b : Reserved, shall not be used. 011b : Passive cable 100b : Active cable 101b...111b : Reserved, shall not be used.
Bit[26]	Modal operation supported : 0 : Otherwise 1 : The product supports modal operation.
Bit[25:16]	0 : Reserved, shall not be used
Bit[15:0]	16-bit unsigned integer. USB vendor ID

Cert Stat VDO

The Cert Stat VDO contains the Test ID (TID) allocated by USB-IF during certification.

Bit(s)	Description
Bit[31: 0]	32-bit unsigned integer, XID

Product VDO

The Product VDO contains identity information relating to the product.

Bit(s)	Description
Bit[31:16]	16-bit unsigned integer. USB Product ID
Bit[15:0]	16-bit unsigned integer. bcdDevice

PD2 Cable VDO

The Cable VDO defined in this section shall be sent when the Product Type is given as Passive or Active Cable.

Bit(s)	Field	Description
Bit[31:28]	Cable HW Version	0000b..1111b assigned by the VID owner
Bit[27:24]	Cable Firmware Version	0000b..1111b assigned by the VID owner
Bit[23:21]	VDO Version	Version number of the VDO Values 000b, 001b, ... 111b are Reserved
Bit[20]	Reserved	0 = Reserved, shall not be used
Bit[19:18]	Type-C to Type-A/B/C	00b = Type-A 01b = Type-B 10b = Type-C 11b = Captive

Bit(s)	Field	Description
Bit[17]	Type-C to Plug/Receptacle	0 = Plug 1 = Receptacle (not valid when B19..18 set to Type-C or Captive)
Bit[16:13]	Cable Latency	0000b : Reserved 0001b : < 10ns (~1m) 0010b : 10ns to 20ns (~2m) 0011b : 20ns to 30ns (~3m) 0100b : 30ns to 40ns (~4m) 0101b : 40ns to 50ns (~5m) 0110b : 50ns to 60ns (~6m) 0111b : 60ns to 70ns (~7m) 1000b : 1000ns (~100m) 1001b : 2000ns (~200m) 1010b : 3000ns (~300m) 1011b1111b : Reserved Includes latency of electronics in active cable
Bit[12:11]	Cable Termination Type	00b = Both ends Passive, VCONN not required 01b = Both ends Passive, VCONN required 10b = One end Active, one end passive, VCONN required 11b = Both ends Active, VCONN required
Bit[10]	SSTX1 Directionality Support	0 = Fixed 1 = Configurable
Bit[9]	SSTX2 Directionality Support	0 = Fixed 1 = Configurable
Bit[8]	SSRX1 Directionality Support	0 = Fixed 1 = Configurable
Bit[7]	SSRX2 Directionality Support	0 = Fixed 1 = Configurable
Bit[6:5]	VBUS Current Handling Capability	00b = VBUS not through cable 01b = 3A 10b = 5A 11b = Reserved
Bit[4]	VBUS through cable	0 = No 1 = Yes
Bit[3]	SOP" controller present	1 = SOP" controller present 0 = No SOP" controller present
Bit[2:0]	USB Super speed Signaling Support	000b = USB 2.0 only 001b = USB3.1 Gen1 010b = USB3.1 Gen1 and Gen2 011b.. 111b = Reserved

PD3 Passive Cable VDO

The Cable VDO defined in this section shall be sent when the Product Type is given as Passive or Active Cable.

Bit(s)	Field	Description
Bit[31:28]	HW Version	0000b..1111b assigned by the VID owner
Bit[27:24]	Firmware Version	0000b..1111b assigned by the VID owner

Bit(s)	Field	Description
Bit[23:21]	VDO Version	Version number of the VDO (not this specification version) : Version 1.0 = 000b Values 001b...111b are Reserved and shall not be used
Bit[20]	Reserved	0= Reserved, shall not be used
Bit[19:18]	USB Type-C plug to USB Type-C/Captive	00b = Reserved, shall not be used 01b = Reserved, shall not be used 10b = USB Type-C 11b = Captive
Bit[17]	Reserved	0= Reserved, shall not be used
Bit[16:13]	Cable Latency	0000b : Reserved, shall not be used 0001b : < 10ns (~1m) 0010b : 10ns to 20ns (~2m) 0011b : 20ns to 30ns (~3m) 0100b : 30ns to 40ns (~4m) 0101b : 40ns to 50ns (~5m) 0110b : 50ns to 60ns (~6m) 0111b : 60ns to 70ns (~7m) 1000b : 70ns (> ~7m) 1001b1111b : Reserved, shall not be used Includes latency of electronics in active cable
Bit[12:11]	Cable Termination Type	00b = VCONN not required. Cable plugs that only support discover identity commands shall set these bits to 00b. 01b = VCONN required 10b...11b = Reserved, shall not be used
Bit[10:9]	Maximum VBUS Voltage	Maximum Cable VBUS voltage : 00b = 20V 01b = 30V 10b = 40V 11b = 50V
Bit[8:7]	Reserved	00b = Reserved, shall not be used
Bit[6:5]	VBUS Current Handling Capability	00b = Reserved, shall not be used 01b = 3A 10b = 5A 11b = Reserved, shall not be used
Bit[4:3]	Reserved	00b = Reserved, shall not be used
Bit[2:0]	USB Super speed Signaling Support	000b = USB 2.0 only, no Super-Speed support 001b = USB 3.1 Gen1 010b = USB 3.1 Gen1 and Gen2 011b...111b = Reserved, shall not be used See USB Type-C 1.2 for definitions

PD3 Active Cable VDO

Bit(s)	Field	Description
Bit[31:28]	HW Version	0000b..1111b assigned by the VID owner
Bit[27:24]	Firmware Version	0000b..1111b assigned by the VID owner

Bit(s)	Field	Description
Bit[23:21]	VDO Version	Version number of the VDO (not this specification version) : Version 1.0 = 000b Version 1.1 = 001b Values 010b...111b are Reserved and shall not be used
Bit[20]	Reserved	0 = Reserved, shall not be used
Bit[19:18]	USB Type-C plug to USB Type-C/Captive	00b = Reserved, shall not be used 01b = Reserved, shall not be used 10b = USB Type-C 11b = Captive
Bit[17]	Reserved	0 = Reserved, shall not be used
Bit[16:13]	Cable Latency	0000b : Reserved, shall not be used 0001b : < 10ns (~1m) 0010b : 10ns to 20ns (~2m) 0011b : 20ns to 30ns (~3m) 0100b : 30ns to 40ns (~4m) 0101b : 40ns to 50ns (~5m) 0110b : 50ns to 60ns (~6m) 0111b : 60ns to 70ns (~7m) 1000b : 70ns (> ~7m) 1001b1111b : Reserved, shall not be used Includes latency of electronics in active cable
Bit[12:11]	Cable Termination Type	00b...01b = Reserved, shall not be used 10b = One end Active, one end passive, VCONN required 11b = Both ends Active, VCONN required
Bit[10:9]	Maximum VBUS Voltage	Maximum Cable VBUS voltage : 00b = 20V 01b = 30V 10b = 40V 11b = 50V
Bit[8]	SBU Supported 0 = SBUs connections supported	0 = SBUs connections supported 1 = SBU connections are not supported
Bit[7]	1 = SBU connections are not supported	When SBU supported = 1 this bit shall be Ignored. When SBU supported = 0 : 0 = SBU is passive 1 = SBU is active
Bit[6:5]	VBUS Current Handling Capability	When VBUS through cable is "No", Reserved, shall not be used. When VBUS though Cable is "Yes" : 00b = Reserved, shall not be used 01b = 3A 10b = 5A 11b = Reserved, shall not be used
Bit[4]	VBUS Through Cable	0 = No 1 = Yes
Bit[3]	SOP" Controller Present	0 = No SOP" controller present 1 = SOP" controller present

Bit(s)	Field	Description
Bit[2:0]	Reserved	00b = Reserved, shall not be used

PD3 Active Cable VDO2 with VDO Version = 1.2

The Cable VDO defined in this section shall be sent when the Product Type is given as Active Cable and VDO version = 1.2.

Bit(s)	Field	Description
Bit[31:24]	Maximum Operating Temperature	The maximum internal operating temperature. It may or may not reflect the plug’s skin temperature.
Bit[23:16]	Shutdown Temperature	The temperature at which the cable will go into thermal shutdown so as not to exceed the allowable plug skin temperature.
Bit[15:6]	Reserved	0...0b = Reserved, shall not be used
Bit[5]	USB 2.0 Supported	0 = USB2.0 supported 1 = USB2.0 not supported
Bit[4]	SuperSpeed Supported	0 = USB3.1 Super-Speed supported 1 = USB3.1 Super-Speed not supported
Bit[3]	SuperSpeed Lanes Supported	0 = One Lane 1 = Two Lanes
Bit[2]	Reserved	0 = Reserved, shall not be used
Bit[1:0]	SuperSpeed Signaling	00b = USB 3.1 Gen1 01b = USB 3.1 Gen2 10 to 11b = Reserved, shall not be used.

Discover SVIDs Responder VDO

The Discover SVIDs Command is used by an Initiator to determine the SVIDs for which a Responder has Modes. The Discover SVIDs Command is used in conjunction with the Discover Modes Command in the Discovery Process to determine which Modes a device supports.

Bit(s)	Field	Description
Bit[31:16]	SVID n	16-bit unsigned integer, assigned by the USB-IF or 0x0000 if this is the last VDO and the Responder supports an even number of SVIDs.
Bit[15:0]	SVID n+1	16-bit unsigned integer, assigned by the USB-IF or 0x0000 if this is the last VDO and the Responder supports an odd number of SVIDs.

Discover MODES

The Discover Modes Command is used by an Initiator to determine the Modes a Responder supports for a given SVID. The SVID in the Discover Modes Command shall be set to the SVID for which Modes are being requested by both the Initiator and the Responder for this Command.

Header No. of Data Objects = 4	VDM Header	Mode 1	Mode 2	Mode 3
-----------------------------------	------------	--------	--------	--------

PD3.0 Get Status

The Get_Status Message is sent by a Port to request Port Partner's present state. The Get_Status Message may also be sent to an Active Cable to get its present status using SOP'/SOP''. The Active Cable shall respond by returning a Status Message.

The Status Message shall be sent in response to a Get_Status Message. The Contents of the Status Message depends on the target of the Get_Status Message. When sent to SOP the Status Message returns the status of the Port's Port Partner. When sent to SOP' or SOP'' the Status Message returns the status of the Active Cable's Plug.

Extended Header Data Size = 2	SDB (2-byte block)
----------------------------------	-----------------------

SOP' Status Data Block

Offset	Field	Value	Description
0	Internal Temp	Unsigned Int	Active Cable Plug's internal temperature in celcius degree. 0 = Feature not supported 1 = Temperature is less than 2 celcius degree. 2 to 255 = Temperature in celcius degree.
1	Flags	Bit field	Bit0 = Thermal shutdown Bit1..Bit7 = Reserved and shall be set to zero

Thermal Considerations

The junction temperature should never exceed the absolute maximum junction temperature $T_{J(MAX)}$, listed under Absolute Maximum Ratings, to avoid permanent damage to the device. The maximum allowable power dissipation depends on the thermal resistance of the IC package, the PCB layout, the rate of surrounding airflow, and the difference between the junction and ambient temperatures. The maximum power dissipation can be calculated using the following formula :

$$P_{D(MAX)} = (T_{J(MAX)} - T_A) / \theta_{JA}$$

where $T_{J(MAX)}$ is the maximum junction temperature, T_A is the ambient temperature, and θ_{JA} is the junction-to-ambient thermal resistance.

For continuous operation, the maximum operating junction temperature indicated under Recommended Operating Conditions is 125°C. The junction-to-ambient thermal resistance, θ_{JA} , is highly package dependent. For a WDFN-8L 2x2 package, the thermal resistance, θ_{JA} , is 45.5°C/W on a standard JEDEC 51-7 high effective-thermal-conductivity four-layer test board. For a WL-CSP-8B 0.96x1.64 (BSC) package, the thermal resistance, θ_{JA} , is 106.5°C/W on a standard JEDEC 51-7 high

effective-thermal-conductivity four-layer test board. The maximum power dissipation at $T_A = 25^\circ\text{C}$ can be calculated as below :

$$P_{D(MAX)} = (125^\circ\text{C} - 25^\circ\text{C}) / (45.5^\circ\text{C/W}) = 2.19\text{W for a WDFN-8L 2x2 package.}$$

$$P_{D(MAX)} = (125^\circ\text{C} - 25^\circ\text{C}) / (106.5^\circ\text{C/W}) = 0.93\text{W for a WL-CSP-8B 0.96x1.64 (BSC) package.}$$

The maximum power dissipation depends on the operating ambient temperature for the fixed $T_{J(MAX)}$ and the thermal resistance, θ_{JA} . The derating curves in Figure 7 allows the designer to see the effect of rising ambient temperature on the maximum power dissipation.

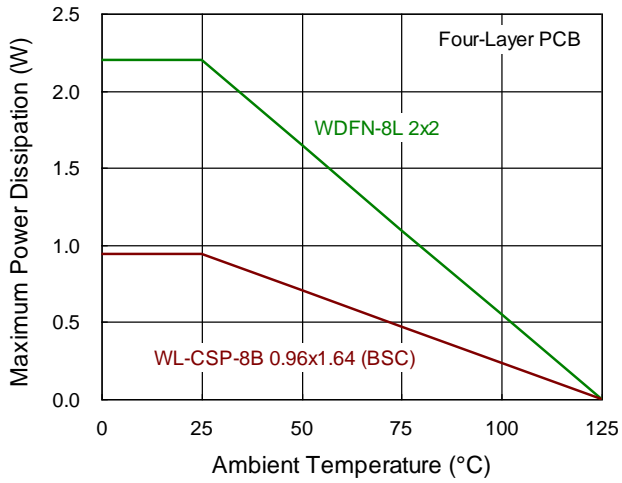
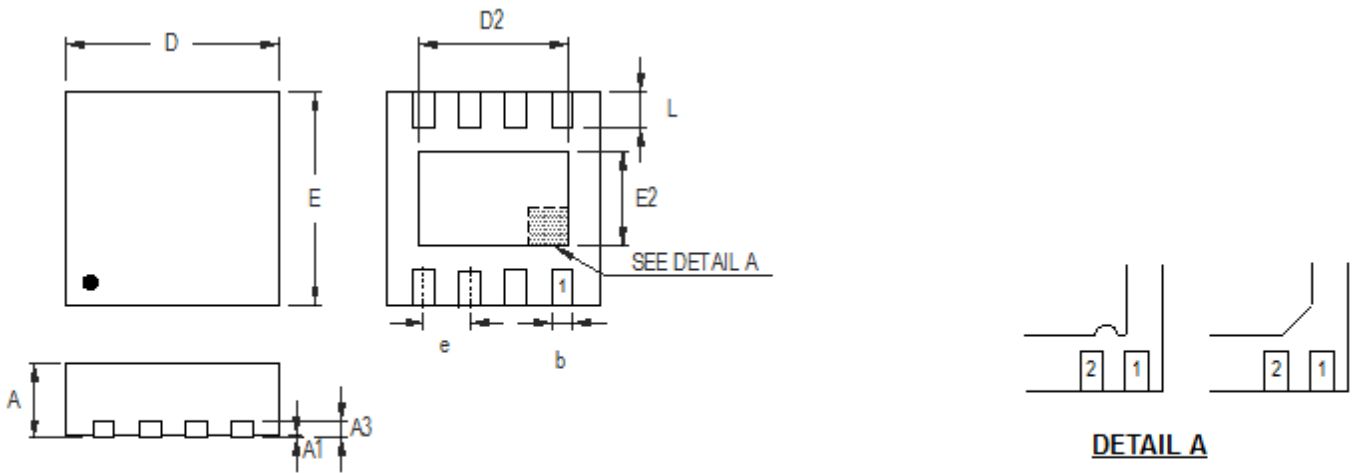

Figure 7. Derating Curve of Maximum Power Dissipation

Layout Considerations

- ▶ PCB layout is very important for designing e-marked IC (RT1731) circuits.
- ▶ Connect VCON1/VCON2 pins with bypass capacitor, and as near the pins as possible.
- ▶ The exposed pad of the chip should be connected to a large ground plane for thermal consideration.
- ▶ Keep the CCIN traces away from those sensing pins (D+, D-, SSTX+, SSTX-, SSRX+, SSRX-, SBU).

Outline Dimension



DETAIL A

Pin #1 ID and Tie Bar Mark Options

Note : The configuration of the Pin #1 identifier is optional, but must be located within the zone indicated.

Symbol	Dimensions In Millimeters		Dimensions In Inches	
	Min	Max	Min	Max
A	0.700	0.800	0.028	0.031
A1	0.000	0.050	0.000	0.002
A3	0.175	0.250	0.007	0.010
b	0.200	0.300	0.008	0.012
D	1.950	2.050	0.077	0.081
D2	1.000	1.250	0.039	0.049
E	1.950	2.050	0.077	0.081
E2	0.400	0.650	0.016	0.026
e	0.500		0.020	
L	0.300	0.400	0.012	0.016

W-Type 8L DFN 2x2 Package

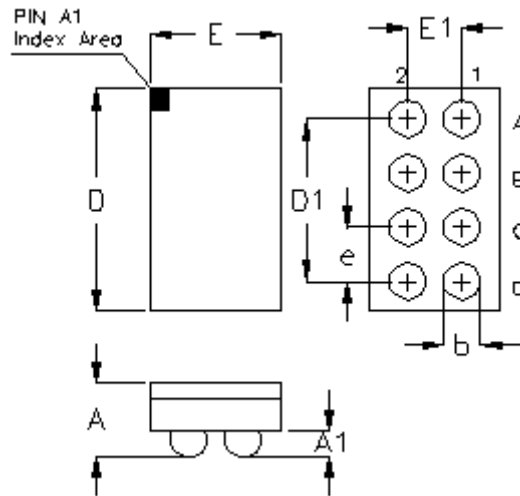

Symbol	Dimensions In Millimeters		Dimensions In Inches	
	Min	Max	Min	Max
A	0.500	0.600	0.020	0.024
A1	0.170	0.230	0.007	0.009
b	0.240	0.300	0.009	0.012
D	1.600	1.680	0.063	0.066
D1	1.200		0.047	
E	0.920	1.000	0.036	0.039
E1	0.400		0.016	
e	0.400		0.016	

8B WL-CSP 0 96x1 64 Package (BSC)

Footprint Information

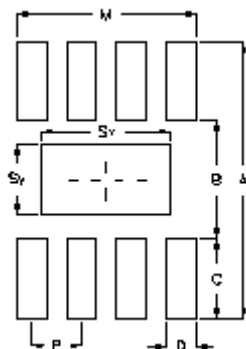

Package	Number of Pin	Footprint Dimension (mm)								Tolerance
		P	A	B	C	D	Sx	Sy	M	
V/W/U/XDFN2*2-8	8	0.50	2.80	1.20	0.80	0.30	1.30	0.70	1.80	±0.05

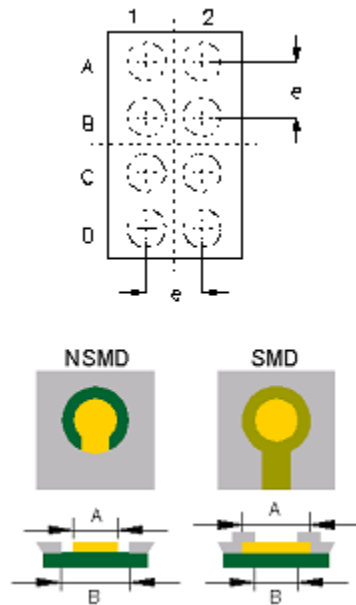

Package	Number of Pin	Type	Footprint Dimension (mm)			Tolerance
			e	A	B	
WL-CSP0.96x1.64-8(BSC)	8	NSMD	0.400	0.240	0.340	±0.025
		SMD		0.270	0.240	

Richtek Technology Corporation

14F, No. 8, Tai Yuen 1st Street, Chupei City
 Hsinchu, Taiwan, R.O.C.
 Tel: (8863)5526789

RICHTEK

Richtek products are sold by description only. Richtek reserves the right to change the circuitry and/or specifications without notice at any time. Customers should obtain the latest relevant information and data sheets before placing orders and should verify that such information is current and complete. Richtek cannot assume responsibility for use of any circuitry other than circuitry entirely embodied in a Richtek product. Information furnished by Richtek is believed to be accurate and reliable. However, no responsibility is assumed by Richtek or its subsidiaries for its use; nor for any infringements of patents or other rights of third parties which may result from its use. No license is granted by implication or otherwise under any patent or patent rights of Richtek or its subsidiaries.

Copyright © 2021 Richtek Technology Corporation. All rights reserved. **RICHTEK** is a registered trademark of Richtek Technology Corporation.